



TRAYFECTA® M Series Former

Cartons, Trays, Cases

packaging **innovation** at work.



Highlights

- **Flexibility:** Handles paperboard and corrugated materials on the same machine; Forms glued, locking, foldover foot-lock and many other retail-ready formats in tray, case, and cartoning applications
- **Speed:** Operates at 50-60+ units per minute depending on the application
- **Heavy-Duty Construction:** Standard stainless steel welded 2"x 4" tubular frame; Oversized shafts and bearings provide long-lasting performance and worry-free operation
- **Precise Tool-Less Changeover:** Tool-less designed quick-insert cavities and heads reduce changeover time to 3 minutes
- **Multiple Forming Heads Boost Throughput:** Offered in 1 or 2 head configurations to meet nearly any line speed requirement; Multi-head formers can produce different types of containers in a single machine cycle
- **High Speed Reliability:** Spring-loaded forming cavities and pneumatic carton ejection cylinders support consistent high-speed performance

TRAYFECTA® M Former

900 series shown below. Please inquire for 1200 and 1500 series measurements.

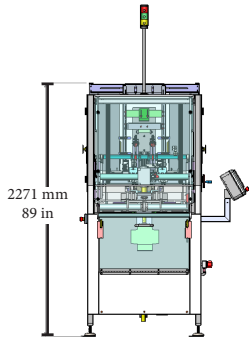

FRONT VIEW

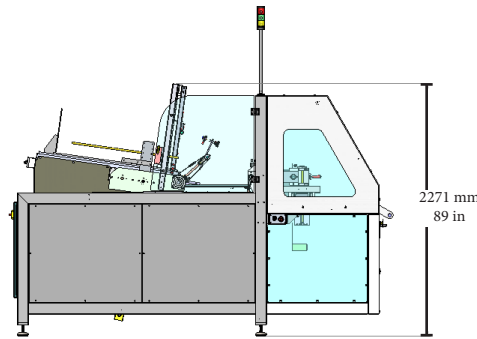

SIDE VIEW

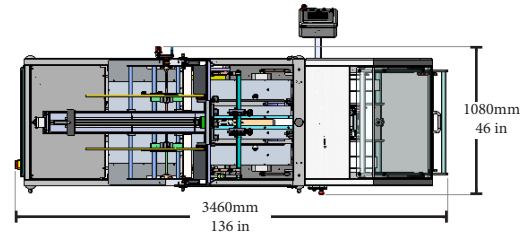

TOP VIEW

	Forming Heads Available	Maximum Units Per Minute	Maximum Blank Width	Maximum Blank Length
900	1	60	24"	32"
1200	1	60	36"	32"
1500	1,2	120	48"	32"

Construction

- 2" x 4" welded stainless steel construction
- Fully counterbalanced precision linkage drive
- NEMA 4 electrical enclosure

Nordson ProBlue 10 Adhesive Melter

Advanced Ergonomics

- Auto-retract pressure plate for blank magazine
- Light-weight forming tools
- Swivel-mount HMI for easy viewing

Utilities

- Electrical Service
480 VAC
50-60 Hz
3-phase
30 amps
- Compressed Air
15 SCFM @ 80psi

Controls and Electronics

- Allen Bradley CompactLogix PLC
- Allen Bradley PanelView Plus 700 color touchscreen HMI
- Allen Bradley Powerflex 4 VFD
- Form-on-demand photo eye
- Adhesive level sensor
- Magazine level sensor
- Discharge verification sensor
- Three-color machine status light tower

Software

- Production monitoring and reporting through color touch screen HMI
- Recipe management system for package setup parameters

Safety

- Interlocked safety guarding
- Non-contact RF switches with safety monitor relay
- Low-voltage control circuitry with touch-safe terminal blocks
- Low/high-voltage panel segregation
- Lockout/Tagout ready air and electrical disconnect
- Filtered air supply with shut-off valve and dump valve
- Two emergency stop buttons
- Overload clutch on main AC drive motor

Training Support

- Machine Orientation provides a smooth hand-off to operators
- Delkor 1080° Training Program provides more formal instruction for machine operation and machine maintenance

Optional Equipment

- NEMA 4X electrical enclosure
- Skirt guarding
- Allen Bradley PanelView Plus 1000 color touchscreen HMI
- Multilingual prompts
- Casters kit
- Ball feet
- Spare parts kit
- Change parts storage cart
- External ethernet and power port on electrical panel
- Crank adjust glue heads
- CAT III Safety